

• General Description

The ZM040N06D combines advanced trench MOSFET technology with a low resistance package to provide extremely low $R_{DS(ON)}$.

• Features

- Advance high cell density Trench technology
- Low $R_{DS(ON)}$ to minimize conductive loss
- Low Gate Charge for fast switching
- Low Thermal resistance

• Application

- SMPS 2nd Synchronous Rectifier
- BLDC Motor driver

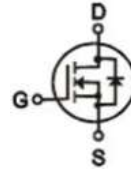
• Product Summary

$V_{DS} = 60V$

$R_{DS(ON)} = 4.6m\Omega$

$I_D = 90A$

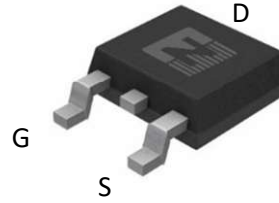

TO-252

• Ordering Information:

Part NO.	ZM040N06D
Marking	ZM040N06
Packing Information	Reel Tape
Basic ordering unit (pcs)	2500

• Absolute Maximum Ratings (T_c = 25°C)

Parameter	Symbol	Rating	Unit
Drain-Source Voltage	V_{DS}	60	V
Gate-Source Voltage	V_{GS}	±20	V
Continuous Drain Current	$I_{D@TC=25^{\circ}C}$	90	A
	$I_{D@TC=75^{\circ}C}$	68	A
	$I_{D@TC=100^{\circ}C}$	57	A
Pulsed Drain Current ^①	I_{DM}	270	A
Total Power Dissipation(TC=25°C)	$P_{D@TC=25^{\circ}C}$	60	W
Total Power Dissipation(TA=25°C)	$P_{D@TA=25^{\circ}C}$	2.0	W
Operating Junction Temperature	T_J	-55 to 150	°C
Storage Temperature	T_{STG}	-55 to 150	°C

•Thermal resistance

Parameter	Symbol	Min.	Typ.	Max.	Unit
Thermal resistance, junction - case	R_{thJC}	-	-	2.05	$^{\circ}C/W$
Thermal resistance, junction - ambient	R_{thJA}	-	-	62.5	$^{\circ}C/W$
Soldering temperature, wavesoldering for 10s	T_{sold}	-	-	265	$^{\circ}C$

•Electronic Characteristics

Parameter	Symbol	Condition	Min.	Typ	Max.	Unit
Drain-Source Breakdown Voltage	BV_{DSS}	$V_{GS} = 0V, I_D = 250\mu A$	60			V
Gate Threshold Voltage	$V_{GS(TH)}$	$V_{GS} = V_{DS}, I_D = 250\mu A$	1.3		2.5	V
Drain-Source Leakage Current	I_{DSS}	$V_{DS} = 60V, V_{GS} = 0V$			1.0	μA
Gate- Source Leakage Current	I_{GSS}	$V_{GS} = \pm 20V, V_{DS} = 0V$			± 100	nA
Static Drain-source On Resistance	$R_{DS(ON)}$	$V_{GS} = 10V, I_D = 16A$		4.6	6	m Ω
		$V_{GS} = 4.5V, I_D = 10A$		6.0	7.5	m Ω
Forward Transconductance	g_{FS}	$V_{DS} = 25V, I_D = 5A$		32		S
Source-drain voltage	VSD	$I_S = 16A$		0.8	1.2	V

•Electronic Characteristics

Parameter	Symbol	Condition	Min.	Typ	Max.	Unit
Input capacitance	C_{iss}	$f = 1MHz$ $V_{DS} = 25V$	-	5300	-	pF
Output capacitance	C_{oss}		-	450	-	
Reverse transfer capacitance	C_{rss}		-	280	-	

•Gate Charge characteristics($T_a = 25^{\circ}C$)

Parameter	Symbol	Condition	Min.	Typ	Max.	Unit
Total gate charge	Q_g	$V_{DD} = 25V$	-	72	-	nC
Gate - Source charge	Q_{gs}	$I_D = 20A$	-	18	-	
Gate - Drain charge	Q_{gd}	$V_{GS} = 10V$	-	21	-	

Note: ① Pulse Test : Pulse width $\leq 300\mu s$, Duty cycle $\leq 2\%$;

Fig.1 Gate-Charge Characteristics

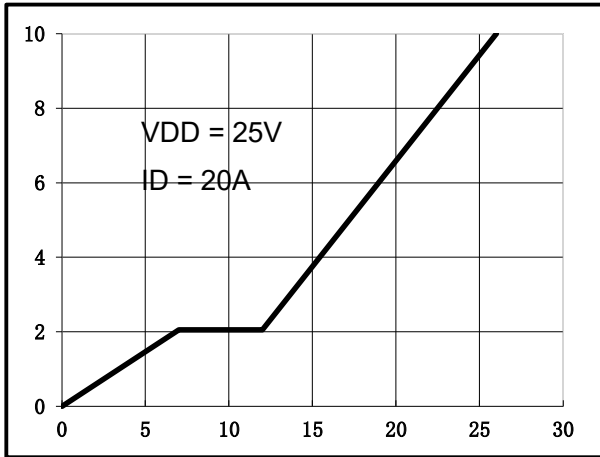

Fig.2 Capacitance Characteristics

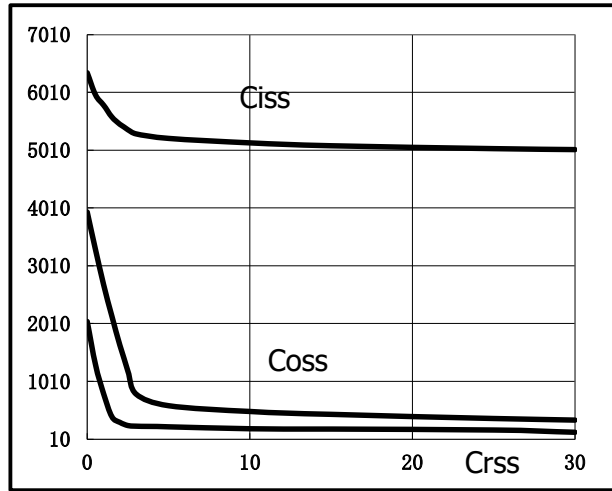

Fig.3 Power Dissipation

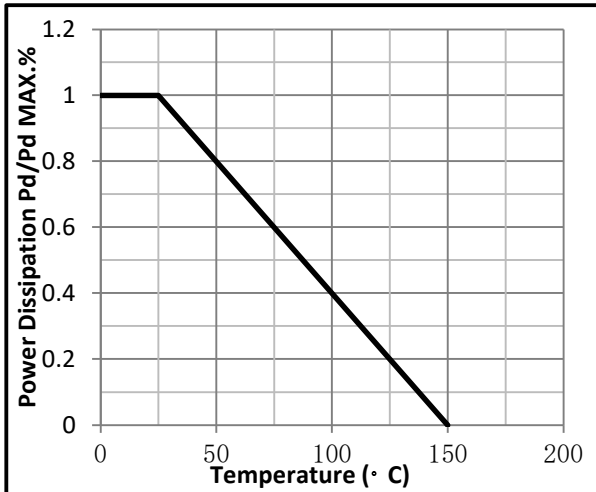

Fig.4 Typical output Characteristics

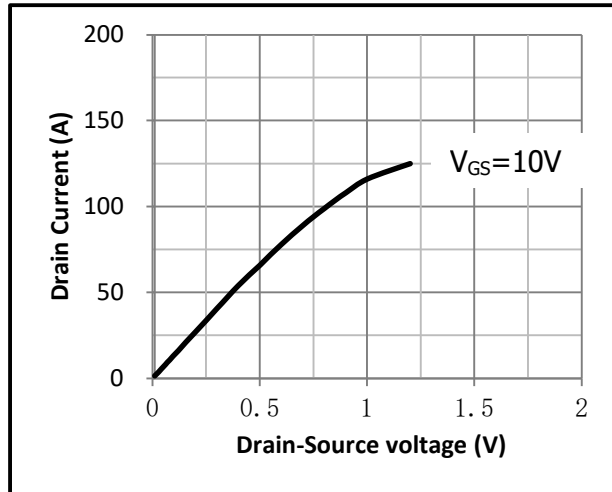

Fig.5 Threshold Voltage V.S Junction Temperature

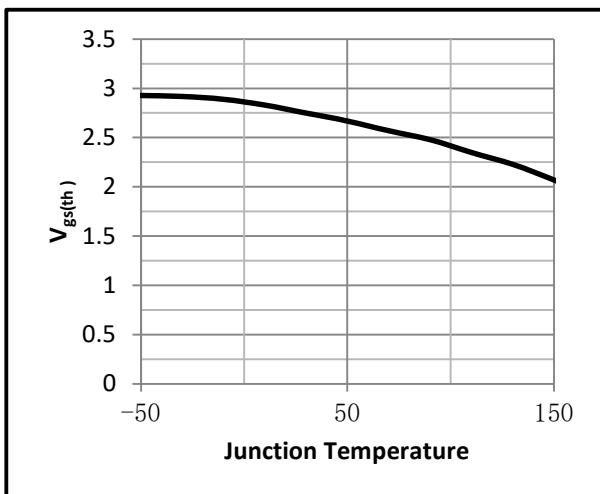

Fig.6 Resistance V.S Drain Current

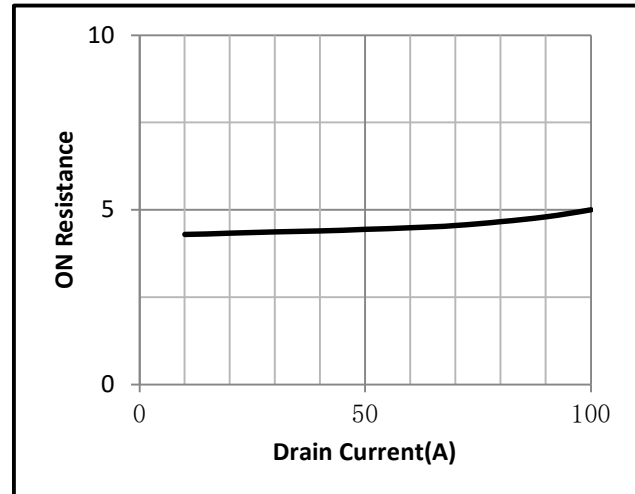

Fig.7 On-Resistance VS Gate Source Voltage

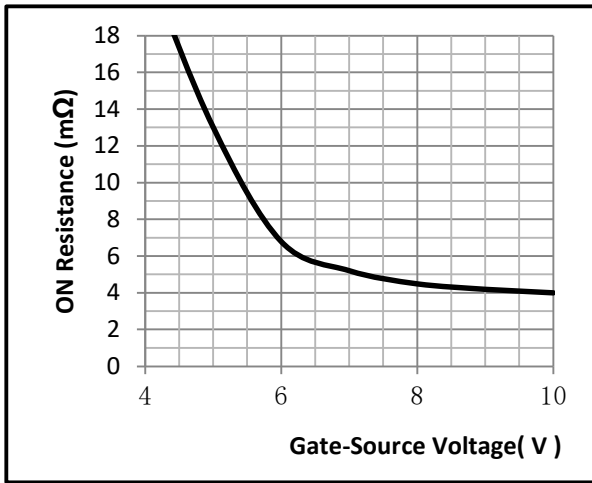

Fig.8 On-Resistance V.S Junction Temperature

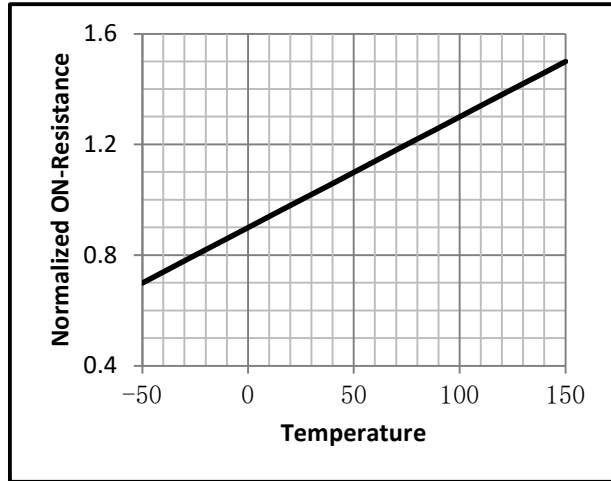

Fig.9 Switching Time Measurement Circuit

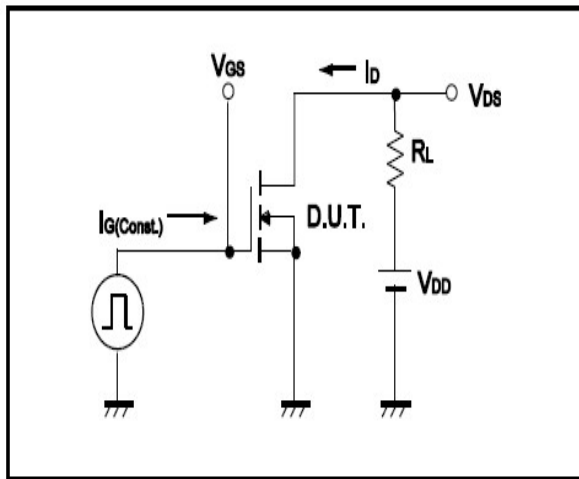

Fig.10 Gate Charge Waveform

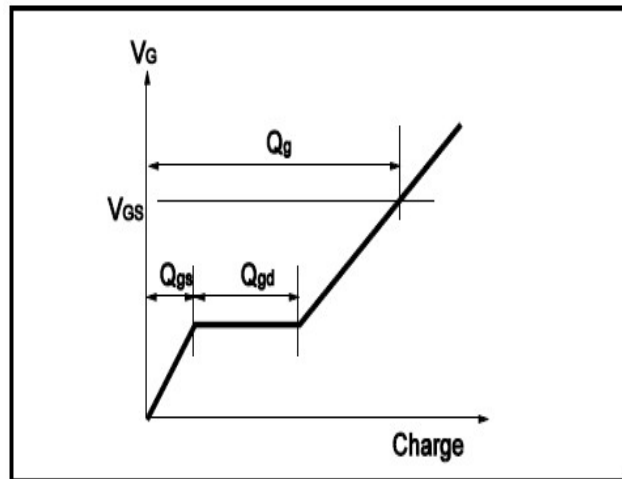

Fig.11 Switching Time Measurement Circuit

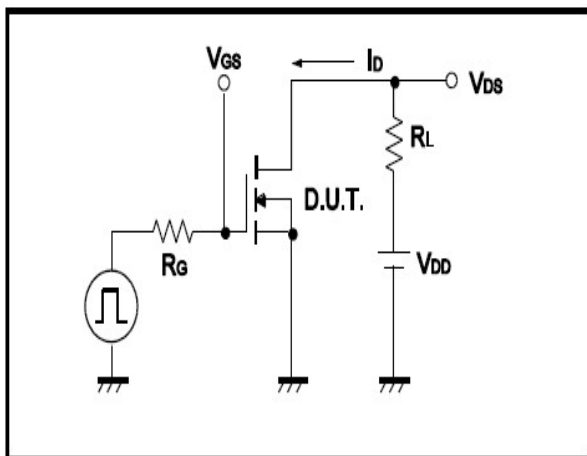
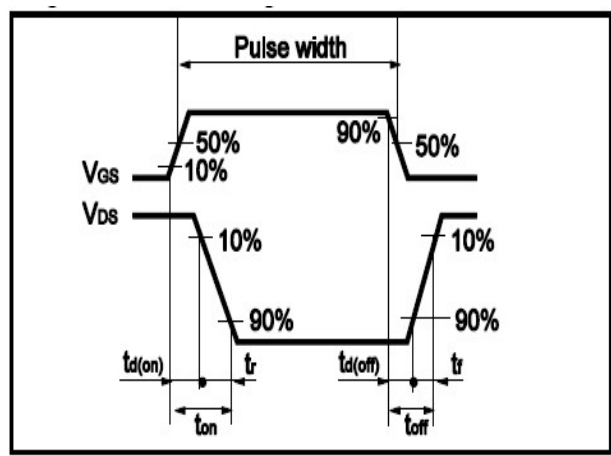
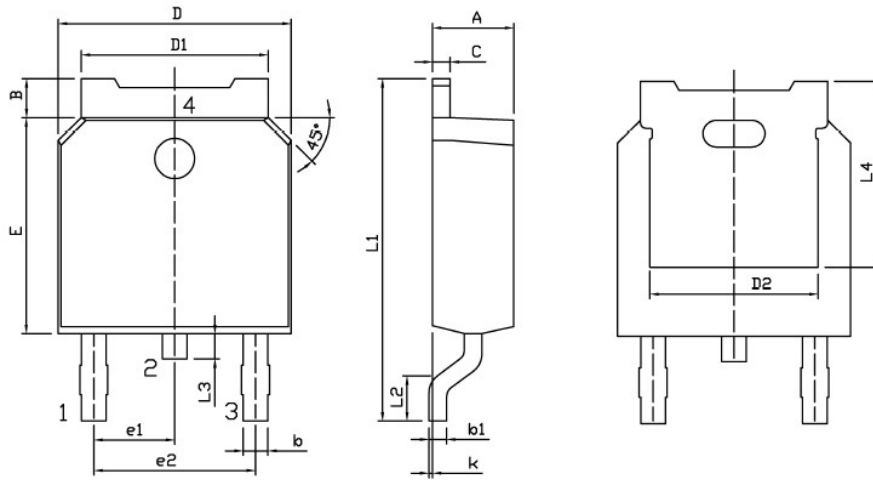

Fig.12 Gate Charge Waveform





• Dimensions (TO-252)



Land Pattern
(Only for Reference)

Dimensions In Millimeters					
Symbol	MIN	MAX	Symbol	MIN	MAX
A	2.20	2.40	E	5.95	6.25
B	0.95	1.25	e1	2.24	2.34
b	0.70	0.90	e2	4.43	4.73
b1	0.45	0.55	L1	9.85	10.35
C	0.45	0.55	L2	1.70	2.00
D	6.45	6.75	L3	0.60	0.90
D1	5.10	5.50	L4	5.05	
D2	4.85		k	0.00	0.10

